

EDUCATION AND TRAINING

CyberSecPro Training

We are creating cutting-edge education and training to advance competencies and professionalism in EU cybersecurity.

OUR VISION

Next level cybersecurity education and training



Co-funded by
the European Union

Protecting Charging Stations Against Specific Threats

CSP008_S_E

PRESENTATION BY:

- CRISTINA ALCARAZ, UNIVERSITY OF MALAGA, SPAIN

EDUCATION AND TRAINING

CyberSecPro Training

We are creating cutting-edge education and training to advance competencies and professionalism in EU cybersecurity.

OUR VISION

Next level cybersecurity education and training



Co-funded by
the European Union

Acknowledgement

- *Co-funded by the European Union. Views and opinions expressed are however those of the author(s) only and do not necessarily reflect those of the European Union or HADEA. Neither the European Union nor the granting authority can be held responsible for them.*
- *Project Agreement no. 101083594*

Protecting Charging Stations Against Specific Threats

Overview

- Topic-1: Introduction to the Energy Charging Infrastructures
- Topic-2: Security Challenges in Energy Charging Stations
- Topic-3: Cascading Effects and impact to other Critical Infrastructures
- Topic-4: Security Measures and Best Practices for Charging Stations

Protecting Charging Stations Against Specific Threats

Overview

- **Topic-1: Introduction to the Energy Charging Infrastructures**
- Topic-2: Security Challenges in Energy Charging Stations
- Topic-3: Cascading Effects and impact to other Critical Infrastructures
- Topic-4: Security Measures and Best Practices for Charging Stations

Energy Charging Infrastructures

- **Electric Vehicles (EVs)** are nowadays a key measure to curb emissions and support sustainability
 - The International Energy Agency (IEA) stresses that 3.0+ million EVs were sold in Europe in 2023, with a remarkable growth since 2016
 - What is more, BP forecasts a considerable increase in sales between now and 2035

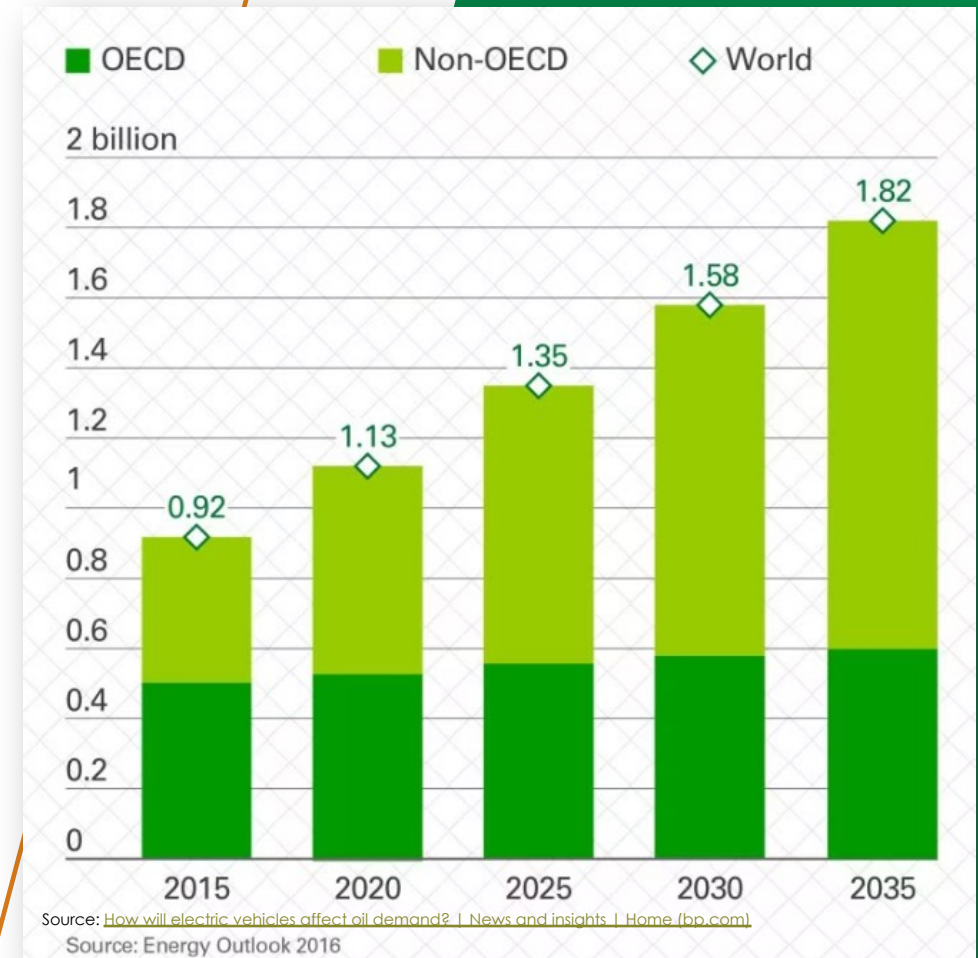
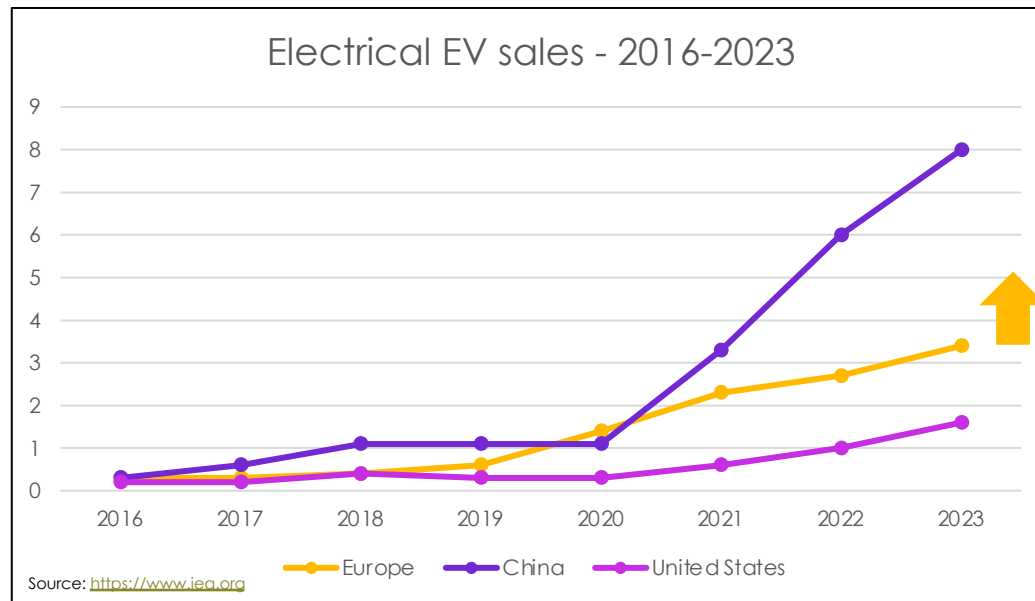

Energy Charging Infrastructures

- Also, the Global Market Insights highlights that “The market size of the EVs charging stations market was valued at USD 38.4 billion in 2023 and is projected to grow between 2024 and 2032 with more than USD 280.5 billion in 2032”

Source: <https://www.iea.org>

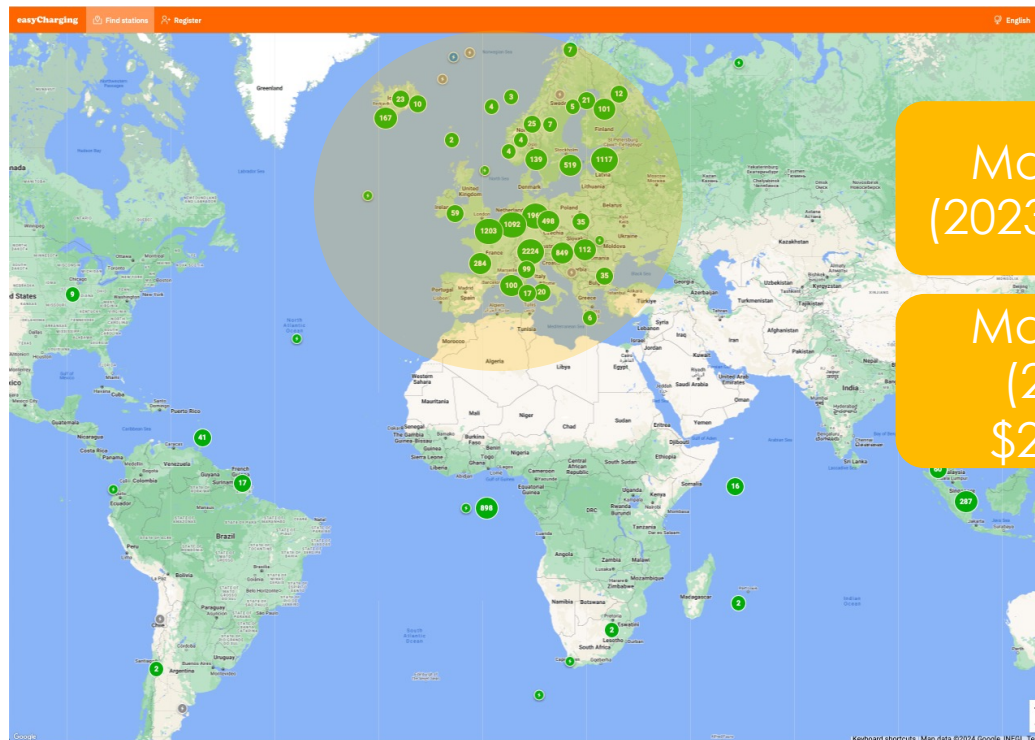

Market Size
(2023): \$38.5BN

Market Size
(2032): >
\$280.5 BN



Energy Charging Infrastructures

- *EV charging infrastructures are composed of:*
 - **Power systems**
 - Distributed Energy Resources (DERs)
 - generators, storage systems, renewable energy systems...
 - Electrical Vehicles (EVs)
 - with batteries and integrated resources

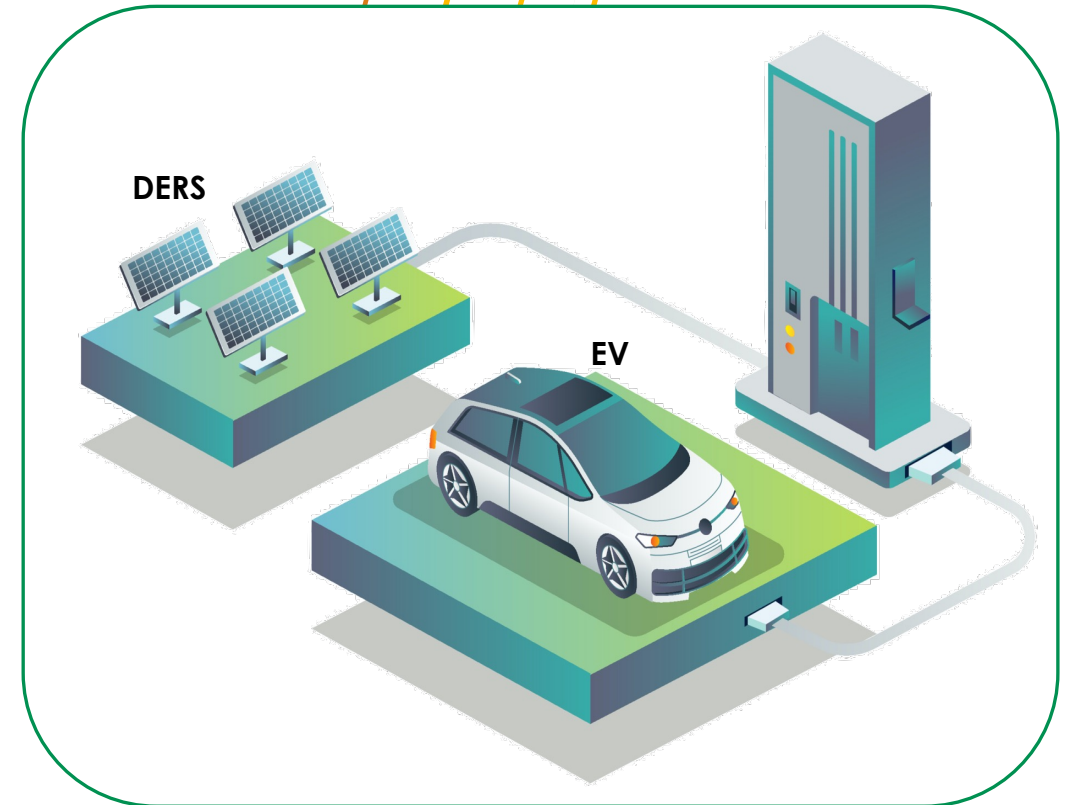

Source: Vecteezy <https://www.vecteezy.com>

Energy Charging Infrastructures

- *EV charging infrastructures are composed of:*

- **Power systems**

- Distributed Energy Resources (DERs)
 - generators, storage systems, renewable energy systems...
- Electrical Vehicles (EVs)
 - with batteries and integrated resources

- **Control systems**

- Central Control System (CCS)
 - CS Management System (CSMS)
 - Energy Management System (EMS)
- Charging Stations (CSs)
 - IT/OT communications
 - Electrical connectors (or EV Supply Equipment (EVSE))
 - Controllers, sensors and smart meters

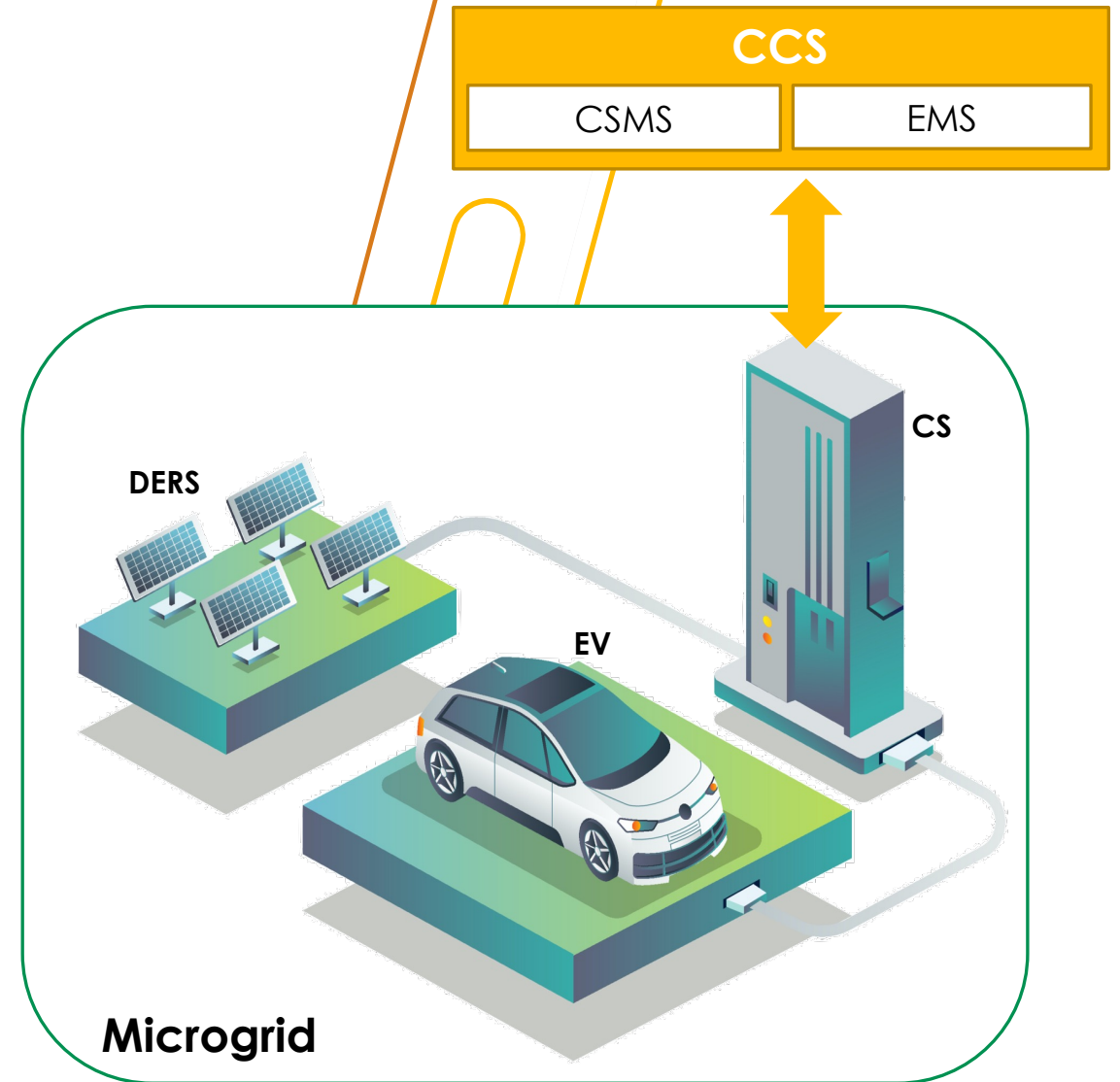

Source: Vecteezy <https://www.vecteezy.com>



Energy Charging Infrastructures

• EV charging infrastructures are composed of

- **Power systems**

- Distributed Energy Resources (DERs)
 - generators, storage systems, renewable energy systems...
- Electrical Vehicles (EVs)
 - with batteries and integrated resources

- **Control systems**

- Central Control System (CCS)
 - CS Management System (CSMS)
 - Energy Management System (EMS)
- Charging Stations (CSs)
 - IT/OT communications
 - Electrical connectors (or EV Supply Equipment (EVSE))
 - Controllers, sensors and smart meters

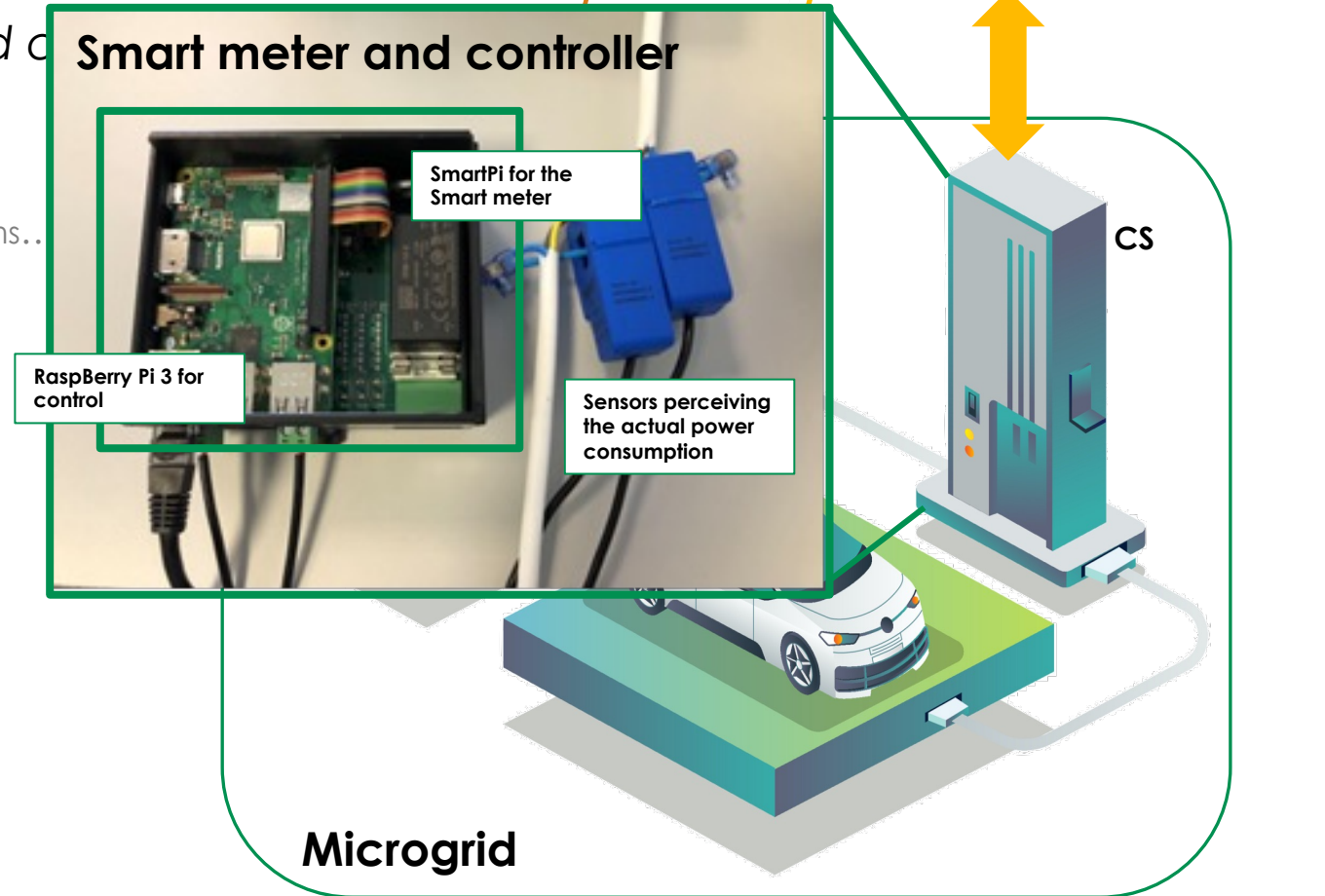

Energy Charging Infrastructures

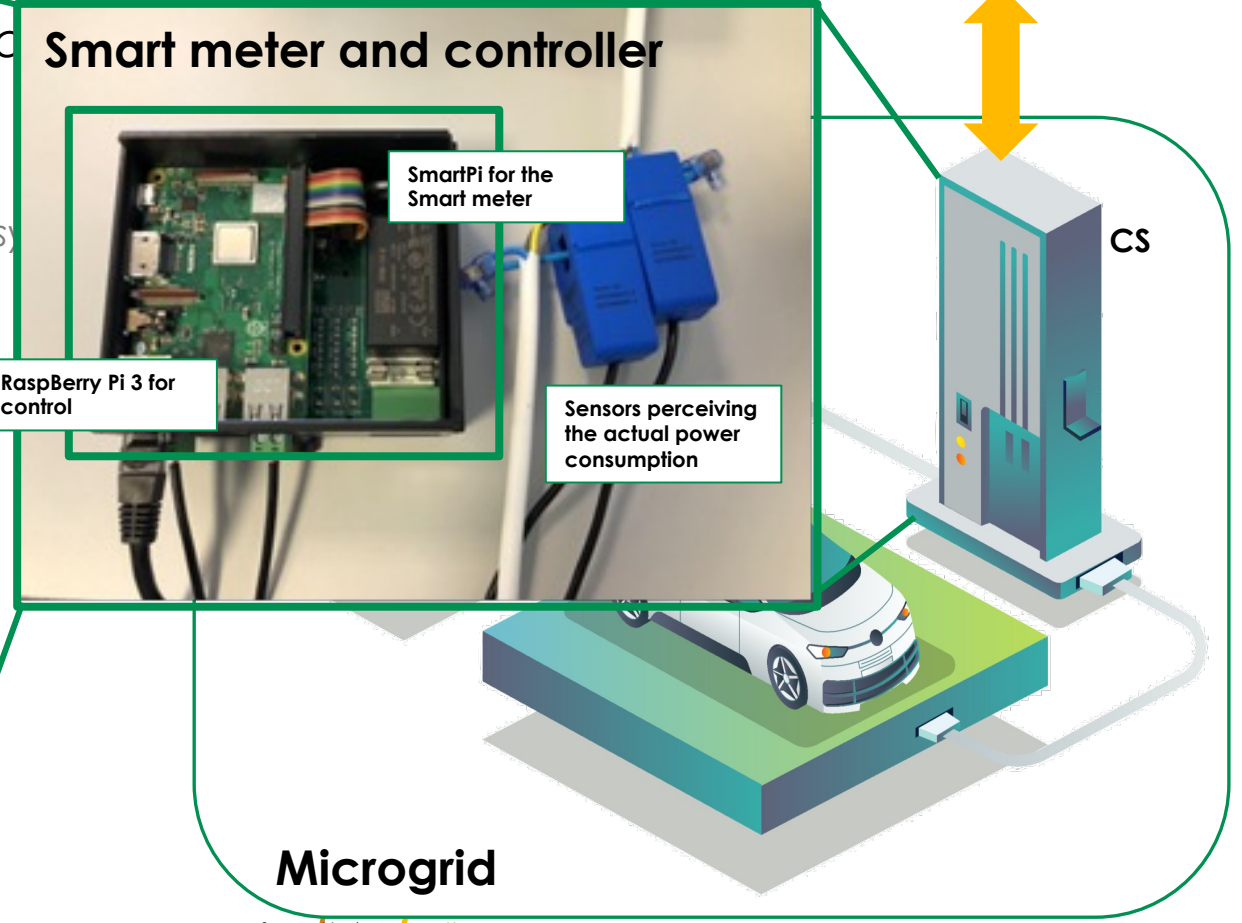
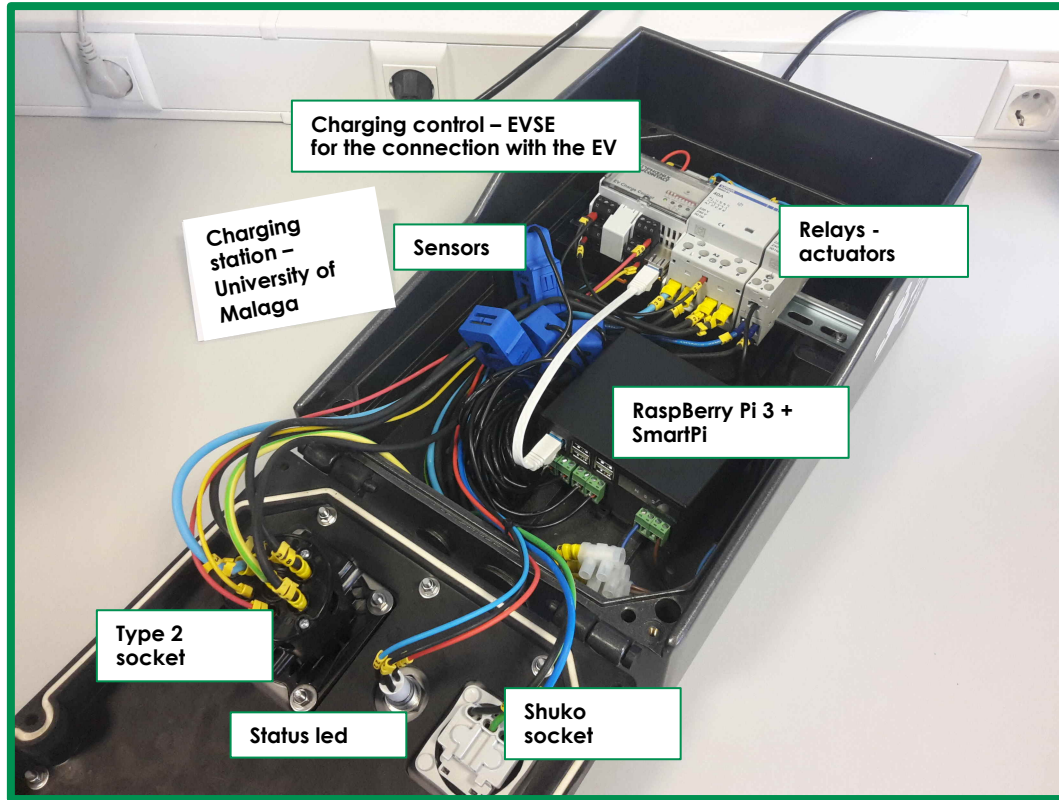

- Electrical connectors for EV supply Equipment (EVSE)
- Controllers, sensors and smart meters

Source: Vecteezy <https://www.vecteezy.com>

CyberSecPro

CC BY NC SA

Energy Charging Infrastructures

- *EV charging infrastructures are composed of:*

- **Power systems**

- Distributed Energy Resources (DERs)
 - generators, storage systems, renewable energy systems...
- Electrical Vehicles (EVs)
 - with batteries and integrated resources

- **Control systems**

- Central Control System (CCS)
 - CS Management System (CSMS)
 - Energy Management System (EMS)
- Charging Stations (CSs)
 - IT/OT communications
 - Electrical connectors (or EV Supply Equipment (EVSE))
 - Controllers, sensors and smart meters

- **Payment systems**

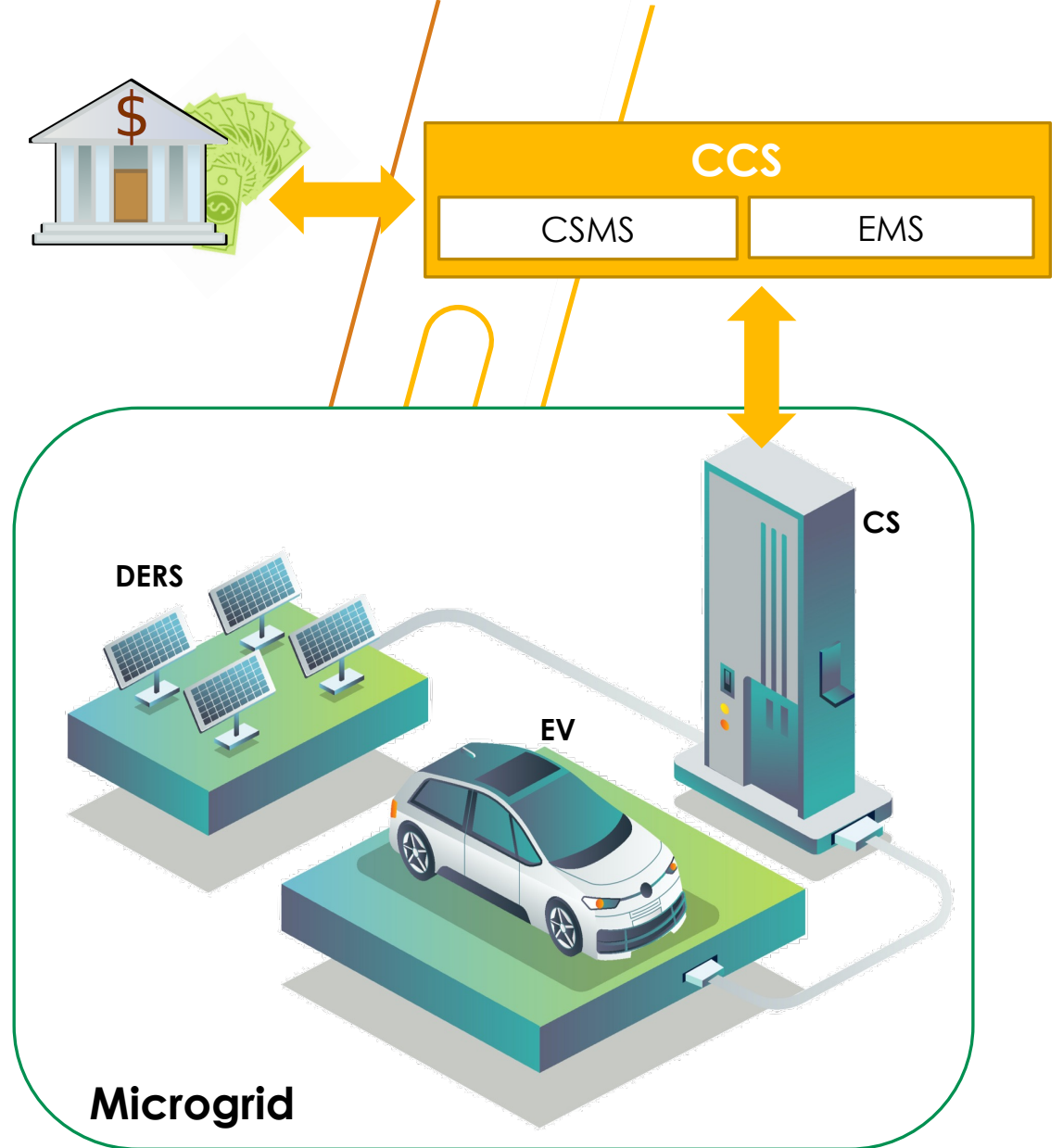

Source: Vecteezy <https://www.vecteezy.com>



Technologies and protocols

• In order to dynamically manage all these systems and their operational processes, it is necessary to deploy various types of information technologies and components

- Internet
- Wireless networks
- Mobile devices
- Firmware
- SW applications
- Web for reservations
- Communication protocols
- ...

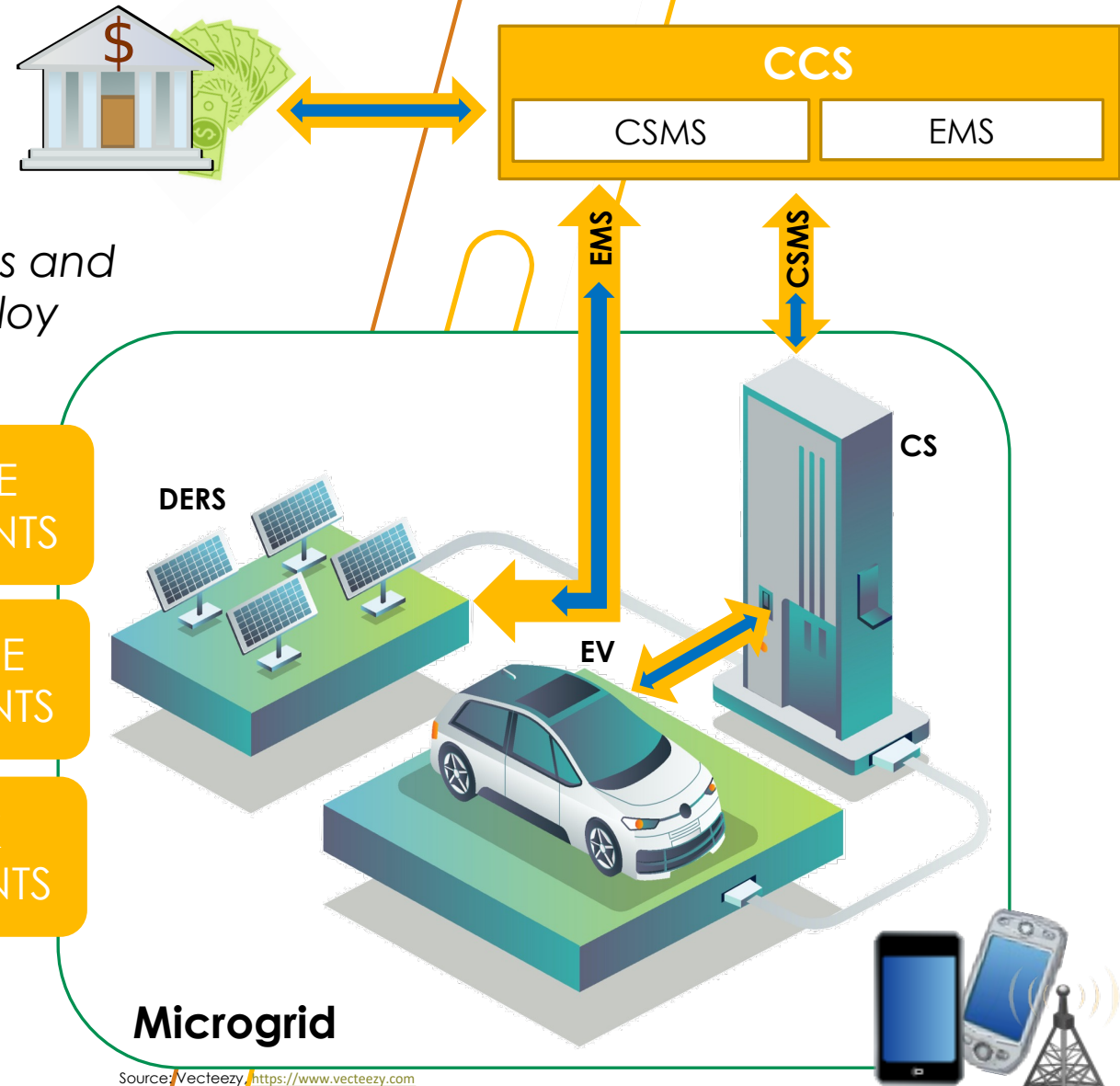
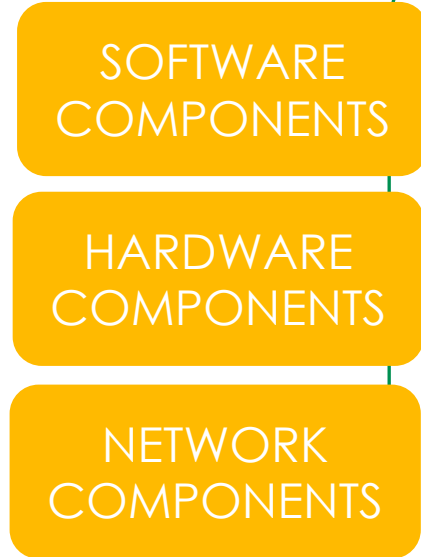

Technologies and protocols

• In order to dynamically manage all these systems and their operational processes, it is necessary to deploy various types of information technologies and components

- Internet
- Wireless networks
- Mobile devices
- Firmware
- SW applications
- Web for reservations
- Communication protocols
- ...

• Among the most standardized protocols, we highlight the Open Charge Point Protocol (OCPP)

SOFTWARE COMPONENTS

HARDWARE COMPONENTS

NETWORK COMPONENTS

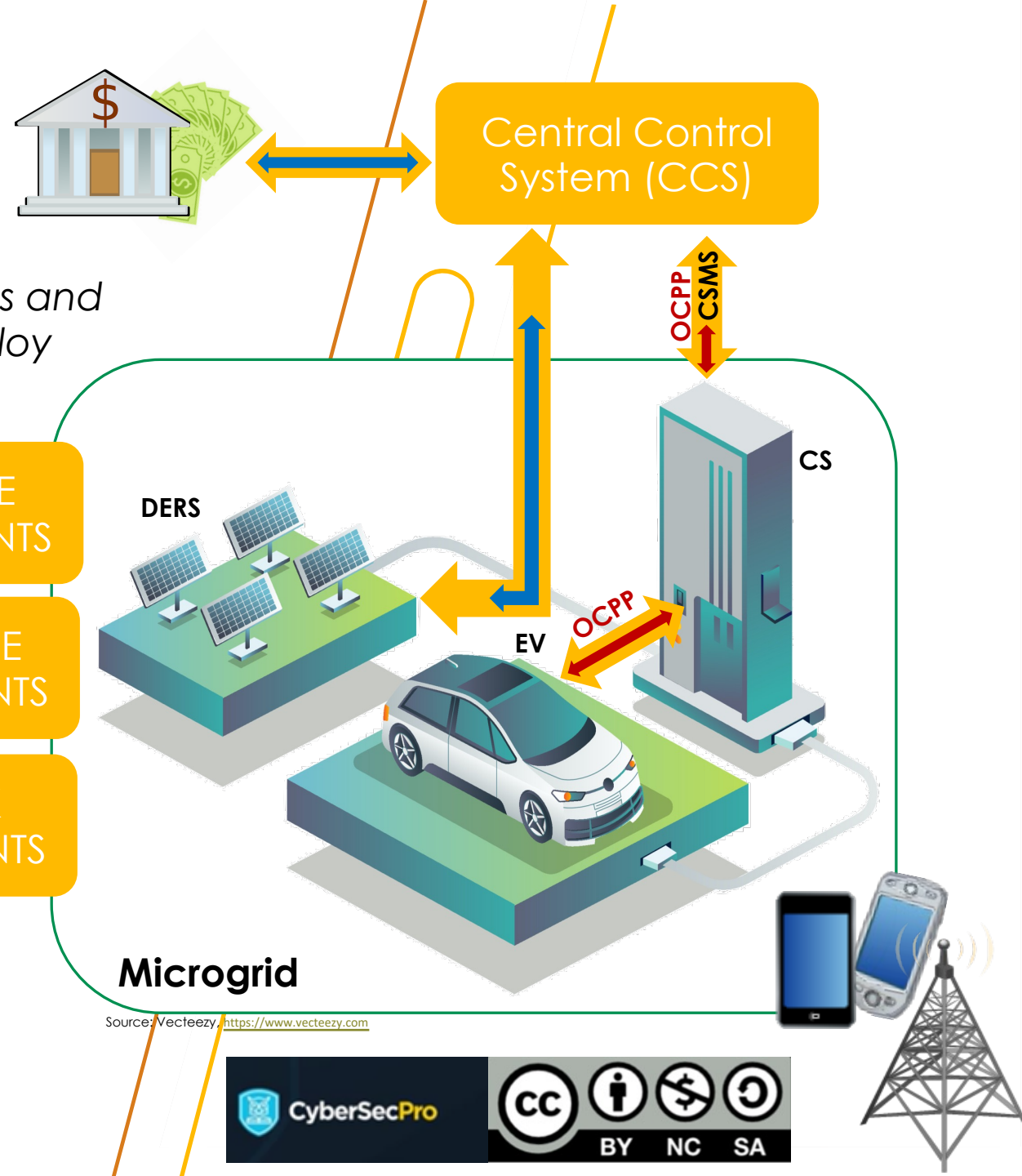

OCPP - Open Charge Point Protocol

- Control protocol for EV charging infrastructure specified by Open Charge Alliance (OCA)

2018

Significant progress in the last few years

OCPP 1.5

- SOAP
- CS operations
- Central system operations
- XML
- Easy to apply

OCPP 1.6

- OCPP 1.5
- SOAP and JSON
- Smart charging with charging profiles
- (Local) list management
- Diagnosis

OCPP 2.0.1

- OCPP 1.6 plus added functionalities
- Device management
- More functions in the transactions
- **Added security**
- Added smart charging functionalities
- Support for ISO 15118
- Display and message support

OCPP Security Profiles

- The OCPP security architecture defines three levels of security profiles:

Profile	Channel encryption	Server Auth	Charger Auth
Security Profile 1	–	–	Password
Security Profile 2	TLS 1.2 or higher	Server Certificate	Password
Security Profile 3	TLS 1.2 or higher	Server Certificate	Client Side Certificate

- Security Profile 2 or Security Profile 3, or both must be implemented to receive OCPP Security implementation.

[Open Charge Point Protocol \(OCPP\) Security Explained \(wevo.energy\)](#), accessed in March 2024

Stakeholders and interests

- In addition to the technologies mentioned above, various types of actors with different interests emerge
 - Customers

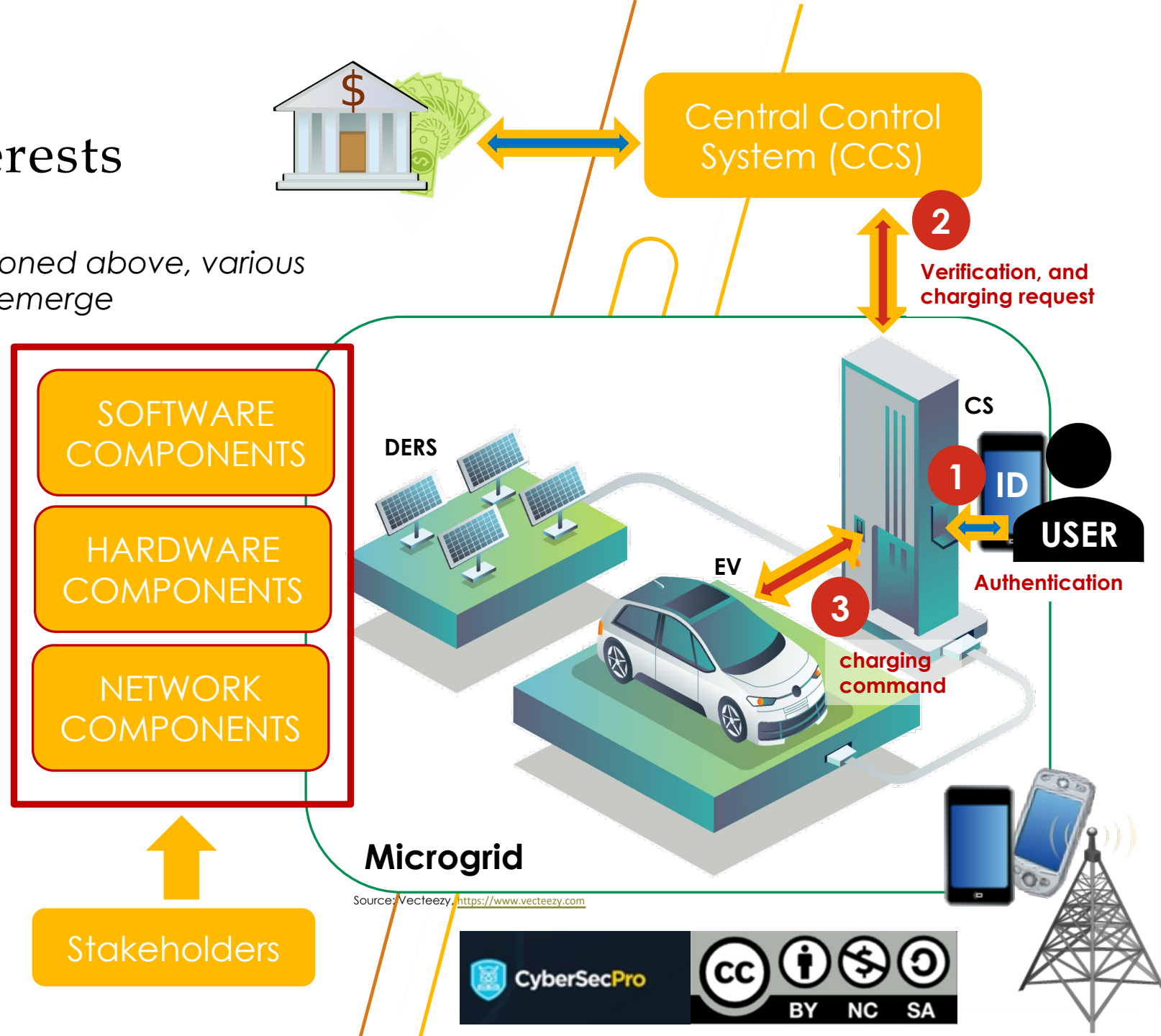

Stakeholders and interests

- In addition to the technologies mentioned above, various types of actors with different interests emerge
 - Customers

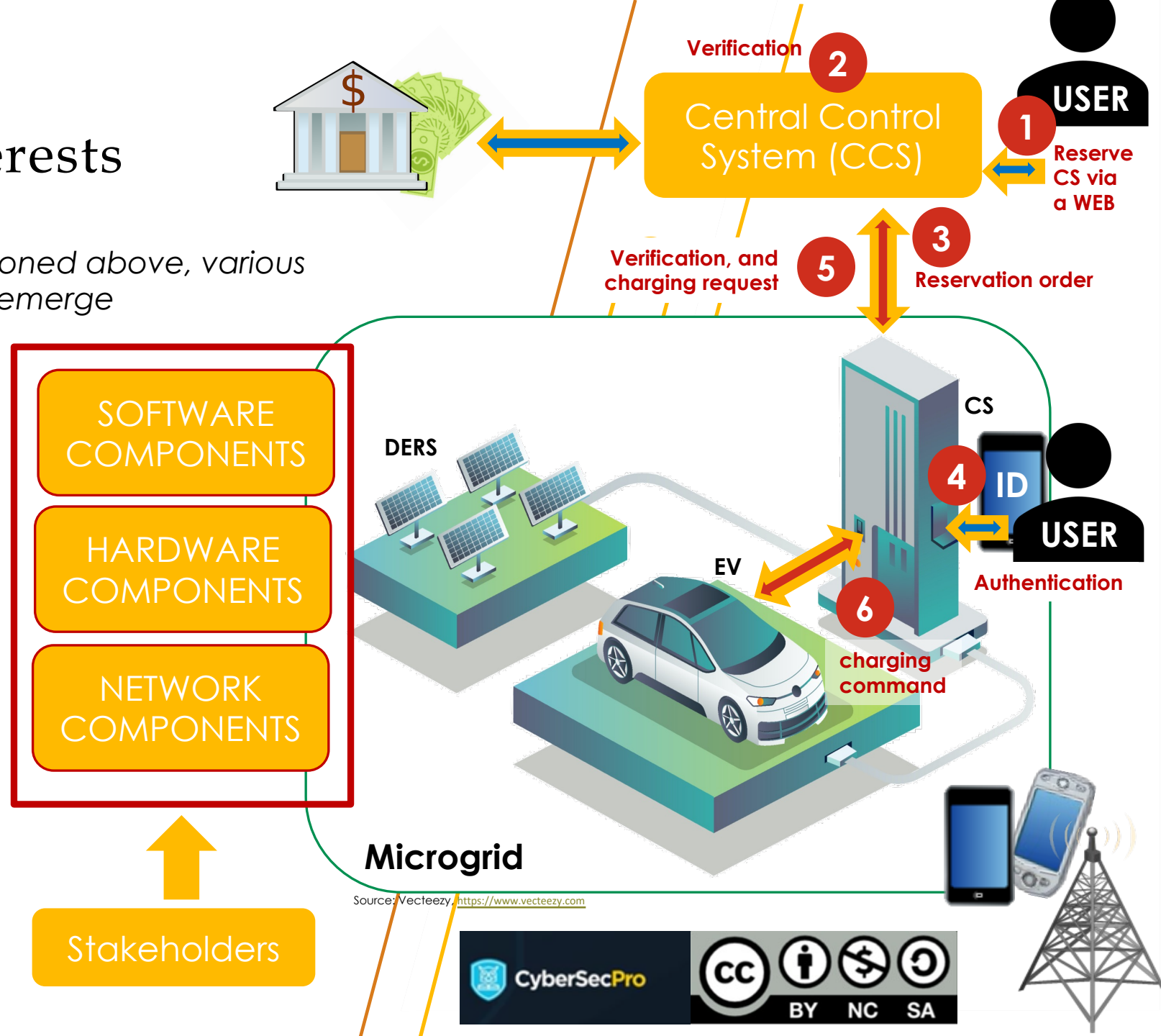

Stakeholders and interests

- In addition to the technologies mentioned above, various types of actors with different interests emerge
 - Customers

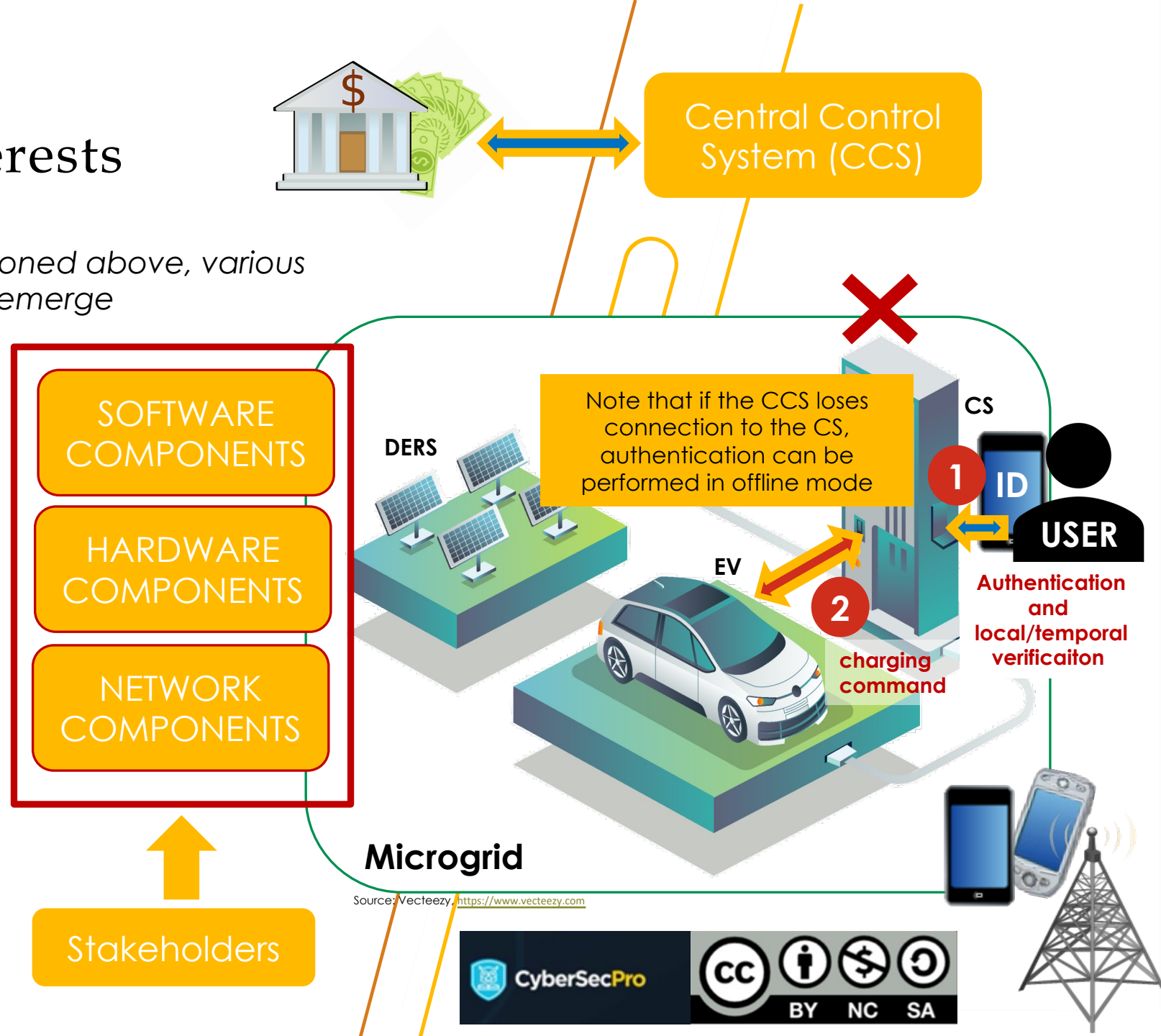

Stakeholders and interests

- In addition to the technologies mentioned above, various types of actors with different interests emerge
 - Customers
 - IT Administrators
 - Charging Station Operator (CSO)

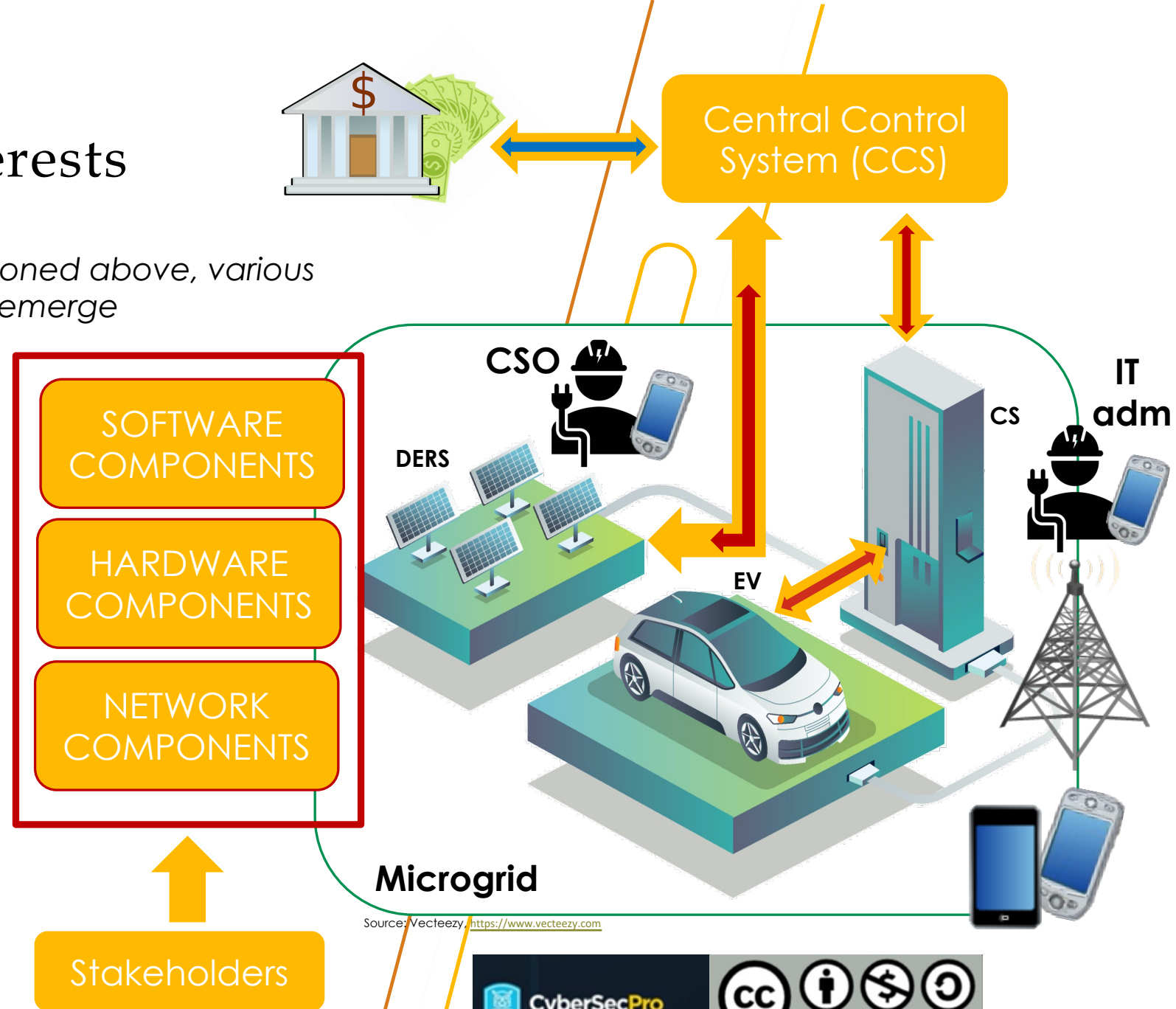

Stakeholders and interests

In addition to the technologies mentioned above, various types of actors with different interests emerge

- Customers
- IT Administrators
- Charging Station Operator (CSO)
- The payment system
- Certificate Authority (CA)
- CS manufacturer and providers
- Law Enforcement personal
- ...
- *All of them making use of new technologies to lead tasks related to*
 - Reserve CS/EVSE
 - Charge
 - Maintenance
 - Supervision and control

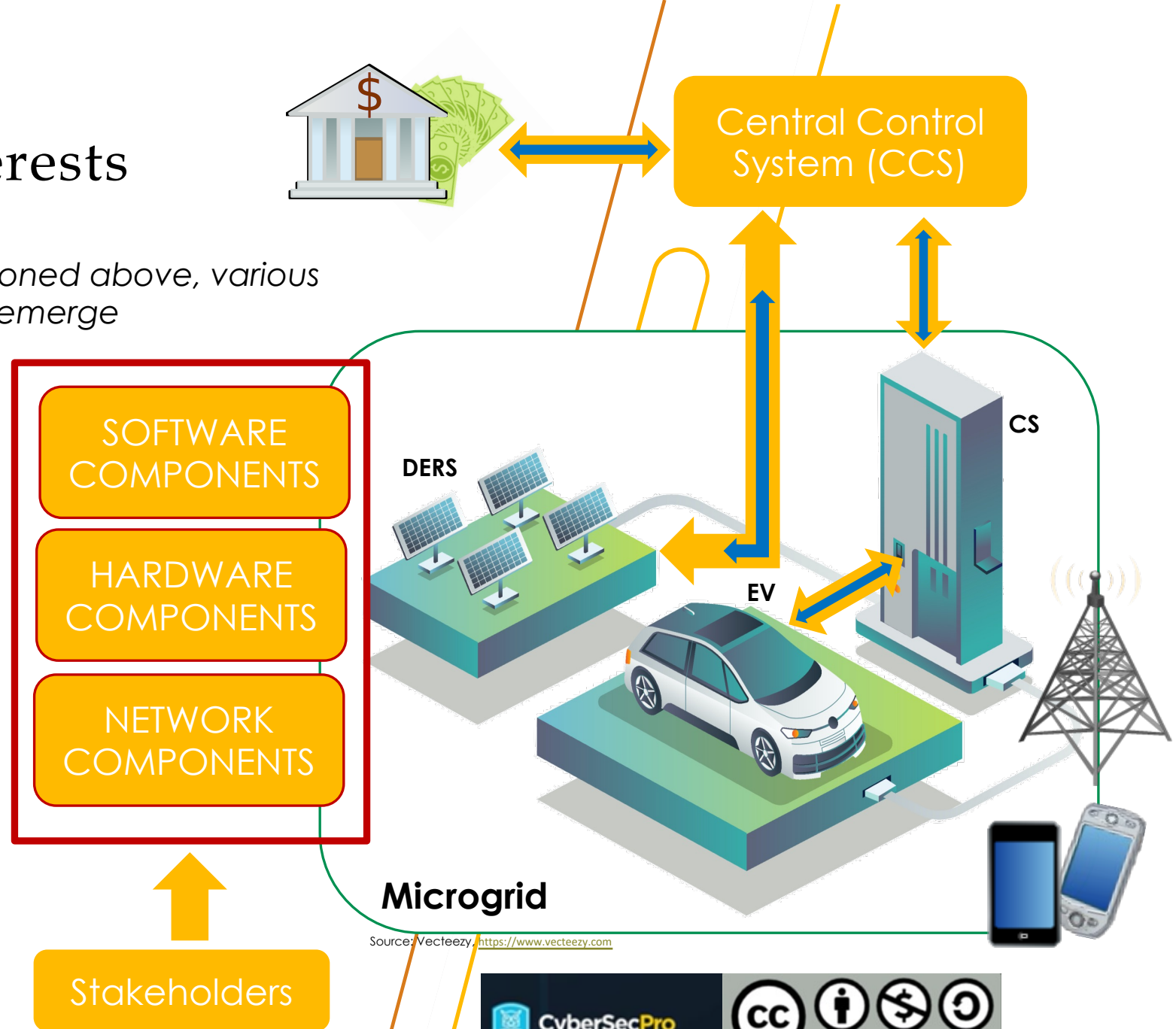

Source: Vecteezy <https://www.vecteezy.com>

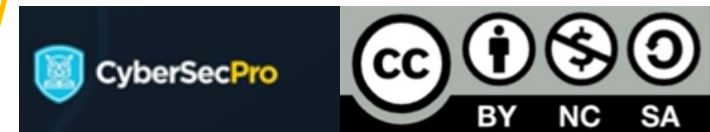

Relationships with other critical infrastructures

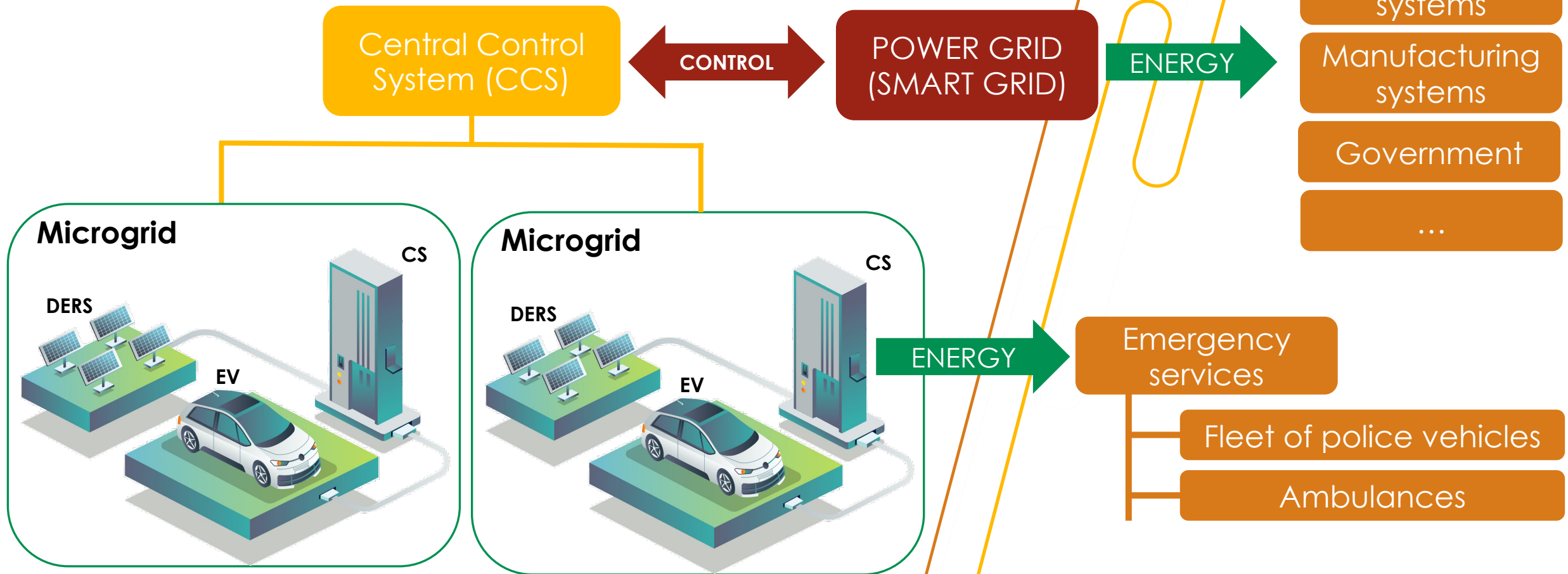

Source: Vecteezy, <https://www.vecteezy.com>

References and sources

1. IEA, Electric Vehicles, 2024
URL: <https://www.iea.org>
2. Global Market Insights (GMI), "Europe Electric Vehicle Charging Station Market Size", 2022
URL: <https://www.gminsights.com/industry-analysis/europe-electric-vehicle-charging-station-market>
3. C. Alcaraz, J. Lopez, and S. Wolthunsen, "OCPP Protocol: Security Threats and Challenges", IEEE Transactions on Smart Grid, vol. 8, pp. 2452 - 2459, 2017
4. C. Alcaraz, J. Cumplido, A. Triviño, "OCPP in the spotlight: threats and countermeasures for electric vehicle charging infrastructures 4.0", International Journal of Information Security, 2023, ISSN: 1615-5262
5. Uri Dorot, "EV Charging Station Applications – a Growing Cyber Security Risk", Radware Blog, 2023
URL: https://www.radware.com/blog/application-protection/2023/05/ev_charging_station_cyber_threats/
6. Figures attributed to Vecteezy, 2024
URL: <https://www.vecteezy.com>
7. DeepL Translator for proofreading.
URL: <https://www.deepl.com/translator>



Connect with CyberSecPro: How to register and other practical information

1. Website:
www.cybersecpro-project.eu
2. X (Twitter):
https://twitter.com/CyberSecPro_eu
3. LinkedIn:
<https://www.linkedin.com/company/cybersecpro-euproject/>



**Co-funded by
the European Union**

Co-funded by the European Union. Views and opinions expressed are however those of the author(s) only and do not necessarily reflect those of the European Union or HADEA. Neither the European Union nor the granting authority can be held responsible for them.

Project Agreement no. 101083594

 ACEEU ACCREDITATION COUNCIL FOR ENTREPRENEURIAL & ENGAGED UNIVERSITIES	 AIT AUSTRIAN INSTITUTE OF TECHNOLOGY	 APIROPLUS SOLUTIONS	 SINTEF	 SOCIAL ENGINEERING ACADEMY	 TAL TECH
ACEEU GmbH Germany Visit Website	AIT AUSTRIAN INSTITUTE OF TECHNOLOGY GMBH Austria Visit Website	APIROPLUS SOLUTIONS LTD Cyprus Visit Website	SINTEF AS Norway Visit Website	Social Engineering Academy GmbH Germany Visit Website	Tallin University of Technology Estonia Visit Website
Logo missing	 COFAC COOPERATIVA DE FORMAÇÃO E ANIMACÃO CULTURAL C.R.L.	 Consiglio Nazionale delle Ricerche	 Technische Universität Braunschweig	 TECHNICAL UNIVERSITY OF CRETE	 trustilio Enhance your Trustworthiness
C2B CONSULTING Italy Visit Website	COFAC Portugal Visit Website	Consiglio Nazionale delle Ricerche Italy Visit Website	Technical University of Braunschweig Germany Visit Website	Technical University of Crete Greece Visit Website	trustilio B.V. The Netherlands Visit Website
 focal point Cyber Defence Exercises as a Service	 GOETHE UNIVERSITÄT FRANKFURT AM MAIN	 ITML	 UNINOVA	 UNIVERSIDAD DE MÁLAGA	 NOVA UNIVERSIDADE NOVA DE LISBOA
FOCAL POINT Belgium Visit Website	Goethe University Frankfurt Germany Visit Website	Information Technology for Market Leadership Greece Visit Website	Uninova Portugal Visit Website	Universidad de Malaga Spain Visit Website	Universidade Nova De Lisboa Portugal Visit Website
 Institut Mines-Télécom	 LAUREA	 GRUPPO Maggioli	 University of Cyprus	 FACULTY OF SCIENCES NOVI SAD 1969 SERBIA	 UNIVERSITY OF PIRAEUS RESEARCH CENTER
Institut Mines-Télecom France Visit Website	Laurea University of Applied Sciences Finland Visit Website	Maggioli S.p.A. Italy Visit Website	University of Cyprus Cyprus Visit Website	University of Novi Sad Faculty of Sciences Serbia Visit Website	University of Piraeus Research Center Greece Visit Website
 PDMFC	 Security Labs Consulting Ltd	 SGI	 Zelus		
PDMFC Portugal Visit Website	Security Labs Consulting Ltd Ireland (Republic) Visit Website	Serious Games Interactive Denmark Visit Website	ZELUS P.C. Greece Visit Website		

Thank you

If you have any questions, please do not hesitate to contact us:

- Cristina Alcaraz
alcaraz@uma.es